

InvenComm GmbH has specialized in the field of management consulting on specific topics:

*Intellectual Property Management*

Patent protection concepts with regard to low cost, optimal lead times and overall protection. Search for licensing partners; sale of property rights.

*Business Plan Development*

Do you have a new business or product idea, we can assist you to get your business plan professionally developed and designed.

*Change Management*

We provide management support to change processes, f.e. succession planning, particularly in corporate design, strategy development and innovation.

*Interim Management*

Management-on-time personnel to bridge personal shortcuts or for the implementation of restructuring.



Please contact us:

**InvenComm GmbH**  
Im Grod 1  
CH-6315 Oberägeri

Phone: 0041 (0) 43 4435472  
Fax: 0041 (0) 43 4435473  
Email: [inven@invencomm.com](mailto:inven@invencomm.com)  
Web: [www.invencomm.com](http://www.invencomm.com)

Your contact: Dipl.-Ing. Thomas Dibke



**InvenComm GmbH**

**Invention Commercialization  
- Consulting**

## About us

InvenComm GmbH was founded in 2002 (in 2004 as GmbH) as invention and a patent commercialization corporation. Corporate purpose is the commercialization of inventions in the field of capital and consumer goods also partly under its own brand. An international network in most continents is used for our proximity to markets.

Our goal is to accompany the inventor from the first designs over the manufacturing up to the marketing of the products.

Since the area of responsibility is steadily expanded and the contracts often more went to the pure consulting area, the business purpose was on customer request extended to the pure business consulting.

- Invention and Patent Commercialization
- Consulting

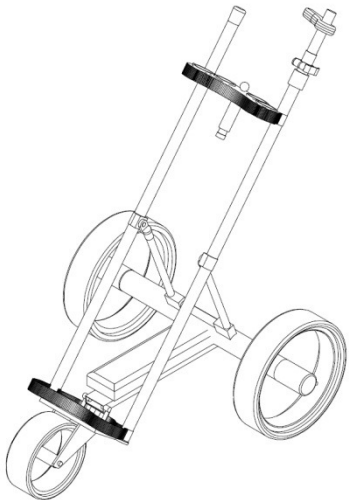

## Services "invention and patent commercialization":

- Search for license partners
- Sales of property rights
- Manufacturing of prototypes
- Construction and development
- Market research
- Production of small series
- Market test
- Tooling
- Marketing concept
- Buildup of sales structure
- Patent right concept (with the patent lawyer)
- Support for business plan generation
- Support for financing

**Ideas are the capital of the future!**

Protect your best ideas and put them strategic into action. We support you!

## Invention and Patent Commercialization

If the marketing strategy decides for sale of the entire property rights or the sale of individual licenses, we are your partner and help you find the appropriate partner. Here you can use our good industry contacts but also technical expertise.

If you use your patent itself for your business, the licensing for other applications or regional markets, in which you yourself are not active, provides the possibility for additional cash from your patent.

We can assist you in preparing the e sales and licensing agreements.

But we wish to emphasize that such sale is only possible when "protected" inventions with sufficient product documentation and completion are available.

One of our specialties is the search for new licensees for rights holders who are dissatisfied with the performance of its licensee. We carry out this task successfully and discretely.

**We talk to potential license or patent buyer directly!**

